



IT INDICE

1. FERRAMENTA 1
 2. INSTALLAZIONE 2

EN CONTENTS





1. HARDWARE KIT 1
 2. INSTALLATION 2

DE INHALTSVERZEICHNIS

1. EISENWAREN-KIT 1
 2. MONTAGE 2

FR INDEX

1. QUINCAILLERIE 1
 2. INSTALLATION 2

- IT** ATTENZIONE:
 Verificare la condizione del supporto prima di installare la specchiera e scegliere viti adeguate al supporto esistente. 
- EN** ATTENTION:
 Check the support condition before proceeding with the installation of the mirror; also choose adequate screw for the existing support. 
- DE** ACHTUNG:
 Vor der installation des spiegels den zustand des halters prüfen; wählen sie angemessene schrauben für bestehenden halter aus. 
- FR** ATTENTION:
 Vérifier les conditions du support avant d'installer le miroir et choisir les vis adéquates au support existant. 

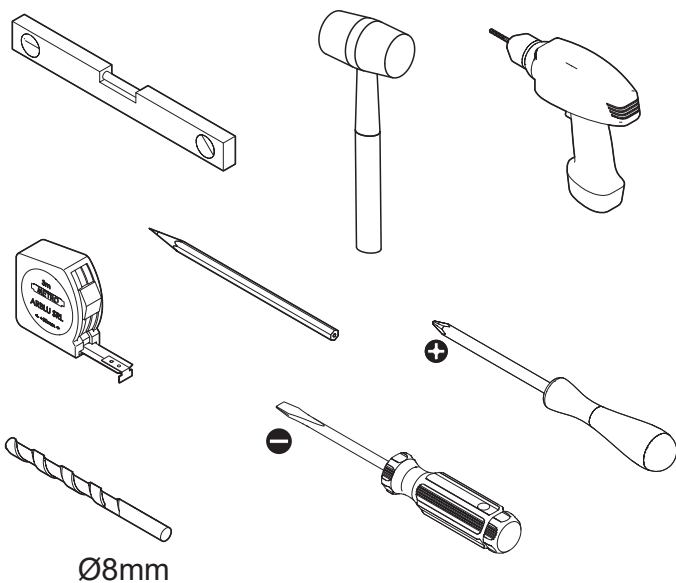

IT FERRAMENTA **EN HARDWARE KIT**
DE EISENWAREN-KIT **FR QUINCAILLERIE**

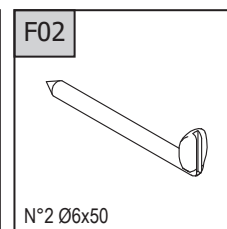
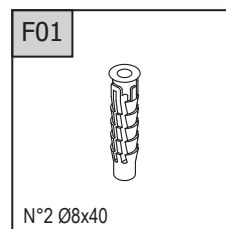

02

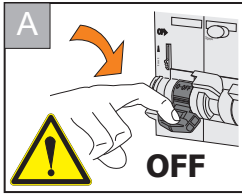

IT Le misure sono espresse in cm
 Tra parentesi le quote consigliate.
EN All measurements are in centimetres.
 In brackets the suggested measures.
DE Abmessungen in Zentimetern (cm).
 In Klammern die empfohlene Vermessungen.
FR Les mesures sont en cm.
 Entre parenthèses les cotes conseillées.

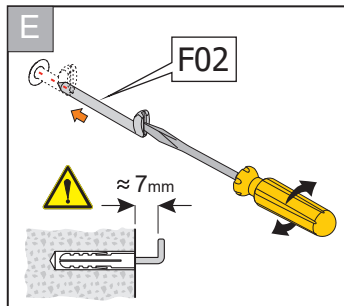
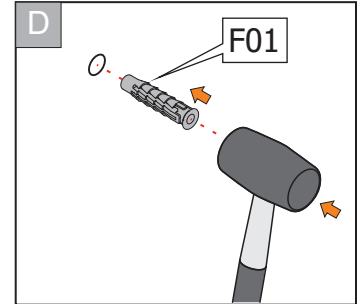
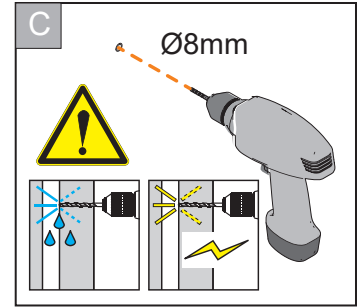
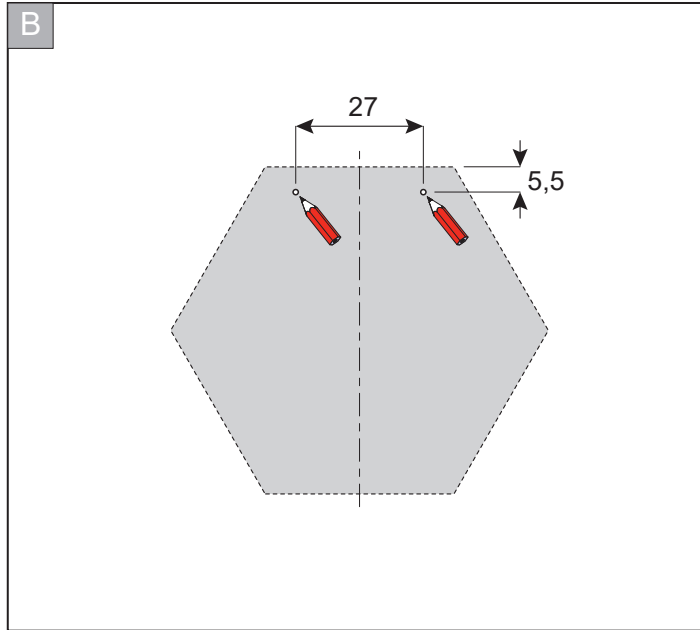
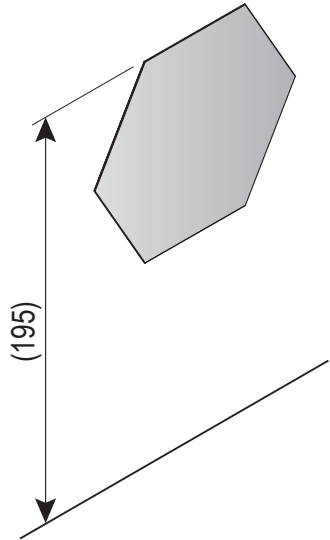

F Se previsto, montare il faretto rispettando le istruzioni fornite in confezione con il faretto e collegarlo, se presente, al Blu Sensor della specchiera (vedi IM000593)
 If required, assemble the spotlight respecting the instructions supplied in the package with the spotlight and connect it, if present, to the Blu Sensor of the mirror (see IM000593)
 Wenn vorgesehen, den Strahler laut Montageanleitung befestigen, und, wenn vorhanden, den Strahler an den Blu Sensor des Spiegels verbinden (siehe IM000593)
 Si nécessaire, installez le spot en suivant les instructions fournies dans l'emballage du spot et connectez-le, s'il est présent, au Blu Sensor du miroir (voir IM000593)

G **ATTENZIONE:** per il collegamento del faretto rispettare le istruzioni fornite in confezione con il faretto.
ATTENTION: to connect the spotlight, follow the instructions supplied in the package with the spotlight.
Bitte beachten: für die Verbindung des Strahlers die Montageanleitung sorgfältig befolgen.
ATTENTION : pour le raccordement du spot, suivez les instructions fournies dans l'emballage du projecteur.

NON INCLUSO
NOT INCLUDED
NICHT INBEGRIFFEN
PAS INCLUS

AVVERTENZE: L'installazione deve essere eseguita da personale professionalmente qualificato e nel rispetto delle vigenti norme sugli impianti elettrici.
WARNING: The installation must be carried out by qualified personnel and in compliance with current regulations on electrical systems.
WARNUNG: Die Montagearbeiten dürfen nur durch qualifiziertes Fachpersonal gemäß den gültigen Richtlinien, Vorschriften und Normen an Elektroanlagen durchgeführt werden.
AVERTISSEMENT: L'installation doit être effectuée par du personnel qualifié et conformément aux réglementations en vigueur regardant les installations électriques.

